



HS-EX6 232 THE SUPERB SERIES



■ UNIQUENESS

■ INNOVATION

■ RESULT

HS-EX6 232 SERIES

Superb efficiency

Introducing the ZERN ENGINEERING HS-EX6 232 — a new leap forward in our series of high-efficiency heat exchangers, taking achievable efficiency to a new level — **superb**.

As this type of heat exchanger is used in residential AHUs with air flow rates up to 700 m³/h, the primary objective in designing this heat exchanger was to **achieve maximum efficiency while maintaining a compact size**.

This has been achieved through a unique and advanced high-efficiency plate profile and improved heat exchanger geometry, which has increased the heat transfer area in each HS-EX6 232 Series heat exchanger.

Heat recovery efficiency at peak points is $\approx 95\%$.

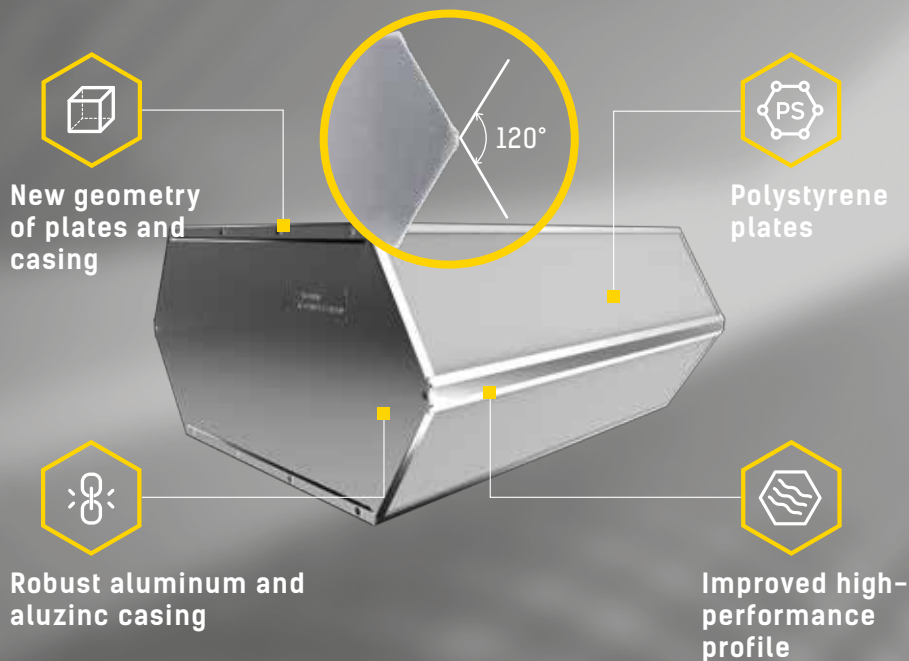

MAIN ADVANTAGES



Superb efficiency

New plate profile + increased heat exchange area = superb efficiency



Good pressure drop

Achieving high efficiency has not compromised the pressure drop, keeping it within optimum limits.



Well-known size of HE on the market

With its popular 461x232mm dimensions, this heat exchanger is designed for easy integration into existing systems, making it an ideal choice for efficient installation and seamless adaptation to a wide range of applications.



Competitive price and production time

We are a customer-focused company, so you can be sure of the best possible terms and conditions.

HS-EX6 232 SERIES DEPENDENCY DIAGRAMS

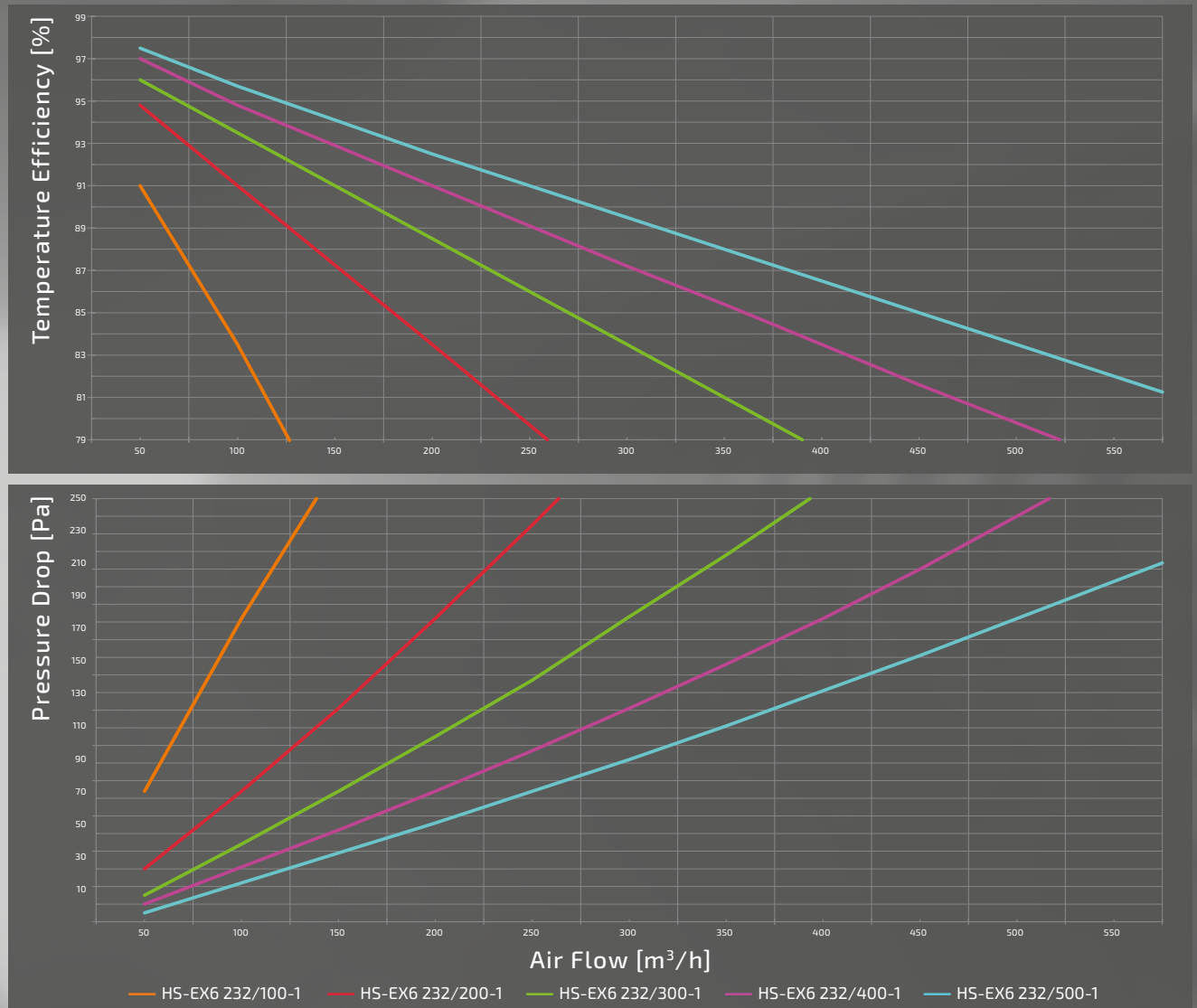

Test results on a HS-EX6 232/100...500-1 model with a depth of 100...500 mm, test conditions according to DIN EN 13141-7 (as well as EN 308)

OVERALL DIMENSIONS

MODEL	DIMENSIONS [MM]			
	A	B	C	Casing design
HS-EX6 232/100...600-1 (1.1) / 3 (3.1)	461	232	100...600	1/1.1 3/3.1

Casing design

- 1 - aluzinc
- 1.1 - aluzinc with a T-profile
- 3 - aluminium
- 3.1 - aluminium with a T-profile

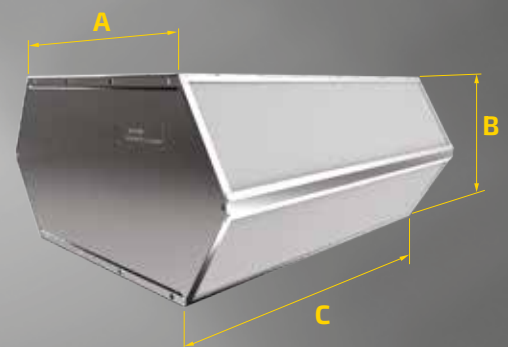

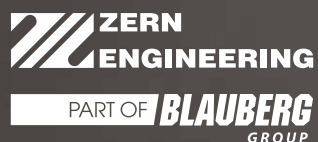

Stäblistraße 6
81477 München

HQ Tel. +49 89 23166620
HQ Fax. +49 89 78069521

sales@zern-engineering.com
zern-engineering.com

The Company reserves the rights to modify any of its products' features, designs, components and specifications at any time and without notice to maintain the development and quality of manufactured goods.